

Tower MiniCrane

Sponsored By
SIEMENS

GOAL: To build a portable, miniature tower crane for educational use that can be controlled via the Internet

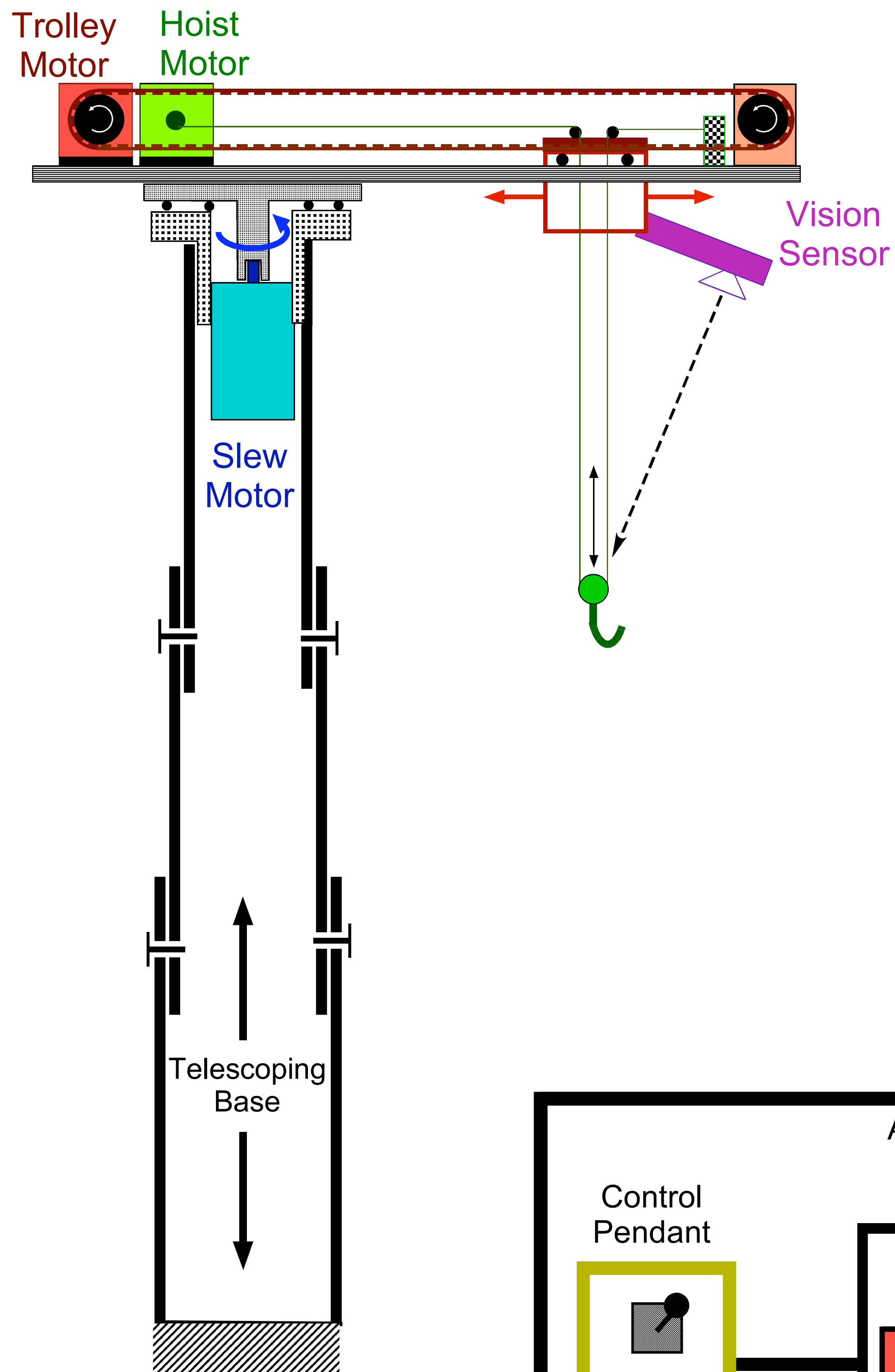

DESIRED FUNCTIONALITY:

- Adjust Controller Parameters Via Internet
- Redesign Controller Architecture Via Internet
- Download Experimental Results Via Internet
- Be able to Conduct Experiments and Demonstrations from Anywhere in the World

SYSTEM OVERVIEW

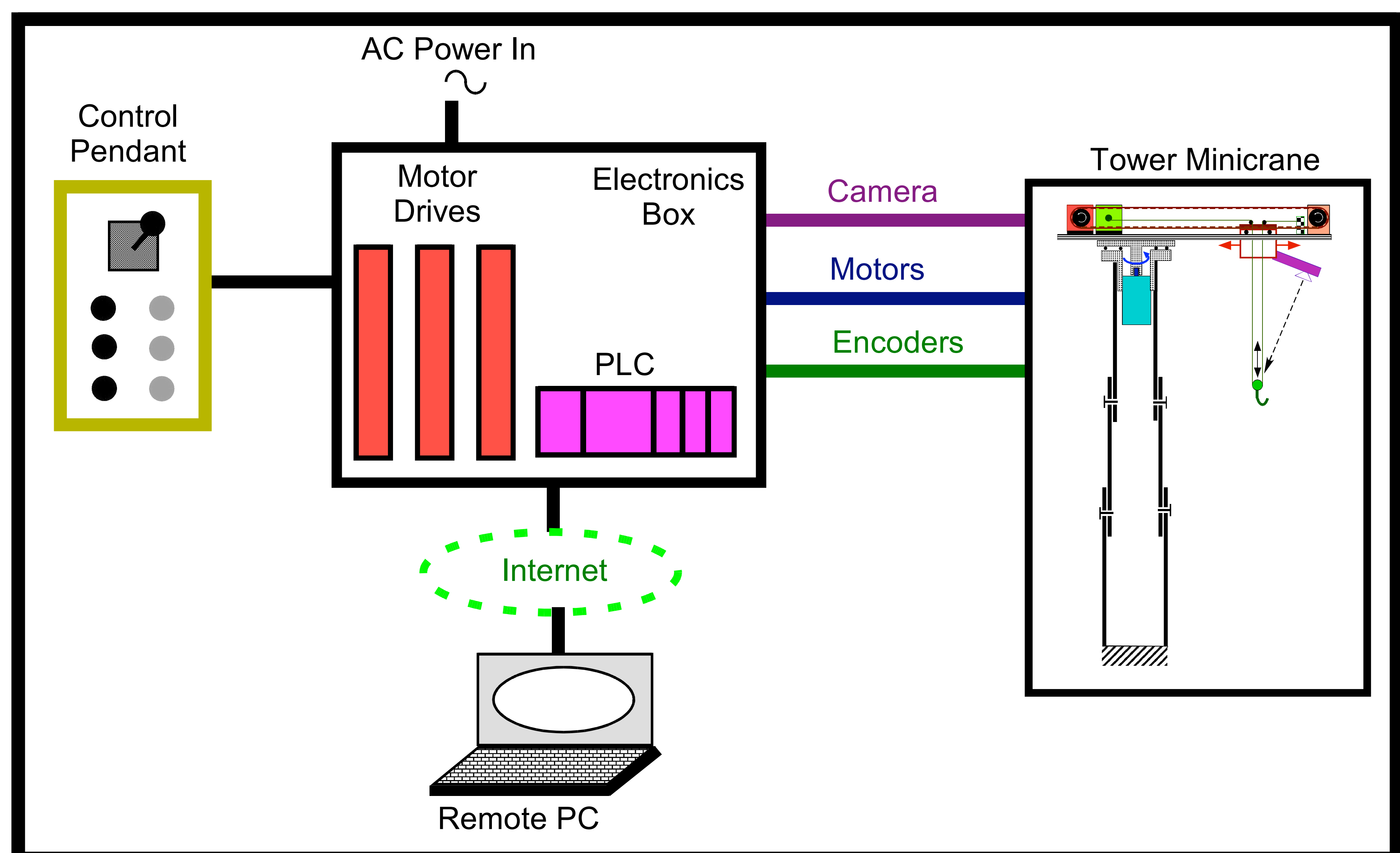

Project Team: William Singhose (Professor), John Huey, Jason Lawrence, Khalid Sorensen